

KRYTAR 180 DEGREE HYBRIDS CONTROL SIGNALS FROM 1 TO 26.5 GHz



Hybrid Couplers perform many functions, including splitting and combining signals in amplifiers, switching circuits, and antenna beam-forming networks. Krytar Hybrid Couplers deliver this versatility from 1 to 26.5 GHz with excellent phase and amplitude matching.

Hybrids are four-port components, with dual input and output ports. A signal applied to the sum (Σ) input port produces two output signals of matched amplitude and phase. Each output level of a Krytar 180 degree hybrid is 3 dB lower (less the insertion loss through the hybrid) than the input level. Signals applied to the difference (Δ) input port produce two equal-amplitude output signals that are 180 degrees out of phase with each other. This characteristic makes such hybrid circuits ideal for reducing noise in amplifiers via feedback combining techniques or for merging multiple signals from arrays. (See table 1 for complete specifications of Krytar 180 degree hybrid couplers).

Table 1: 3 dB 180 Degree Hybrid Couplers

Model	Frequency Range (GHz)	Coupling (dB)	Amplitude Imbalance (dB)	Phase Imbalance (Degrees)	Isolation (dB Min)	Maximum VSWR	Insertion Loss (dB Max)
4020080	2 - 8	3	± 0.3	± 8	18	1.4	1.1
4040124	4 - 12.4	3	± 0.4	± 8	17	1.6	0.9
4010124	1 - 12.4	3	± 0.4	± 10	17	1.6	2.1
4020180	2 - 18	3	± 0.6	± 14	15	1.7	2.0
4010180	1 - 18	3	± 0.6	± 12	15	1.7	2.9
4060200	6 - 20	3	± 0.6	± 10	15	1.7	1.2
4060265	6 - 26.5	3	± 0.7	± 12	14	1.7	1.6

KRYTAR 180 DEGREE HYBRIDS CONTROL SIGNALS FROM 1 TO 26.5 GHz

The hybrids were designed with a double arrow construction technique in which two stripline, 8.34-dB asymmetric, tapered-line directional couplers are cascaded. Meandering transmission lines on each side of the hybrid maintain the even 180 degree phase relationship between channels at all frequencies. Fabrication of the double-arrow hybrids requires an asymmetric coupler with completely overlapped lines at its coupled end (where the lines cross) that form an instantaneous transition from high coupling to no coupling. The hybrids are realized with a three-layer stripline configuration. Coupled lines are etched on opposite sides of a thin coupler circuit board, sandwiched between a pair of equal thickness Duroid boards.

Systems such as antenna beam-forming networks can be designed more efficiently with 180 degree hybrids. The double-arrow configuration of Krytar 180 degree hybrids yields very broadband Phase and Amplitude imbalance (Figure 1) performance and permits design of broadband beam-forming networks (Figure 2) with low parts count. for a typical EW beam forming network housed in a single, compact enclosure. Krytar works with individual companies to design these networks for special applications.

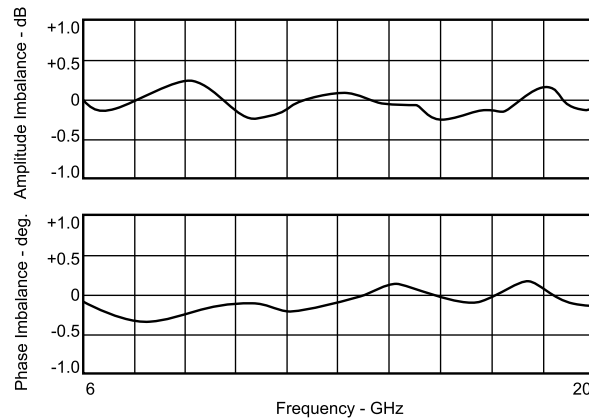

Figure 1: Phase and amplitude imbalance for the model 4060200 hybrid were measured from 6 to 20 GHz with an automatic vector network analyzer.

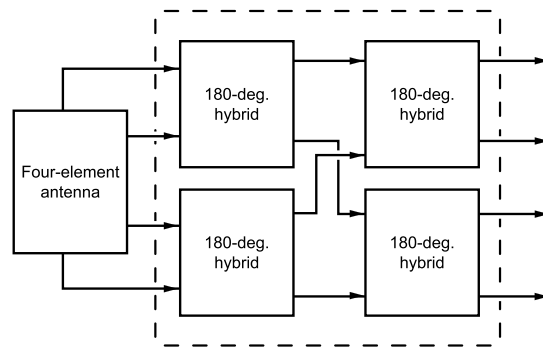

Figure 2: Beam Forming Network