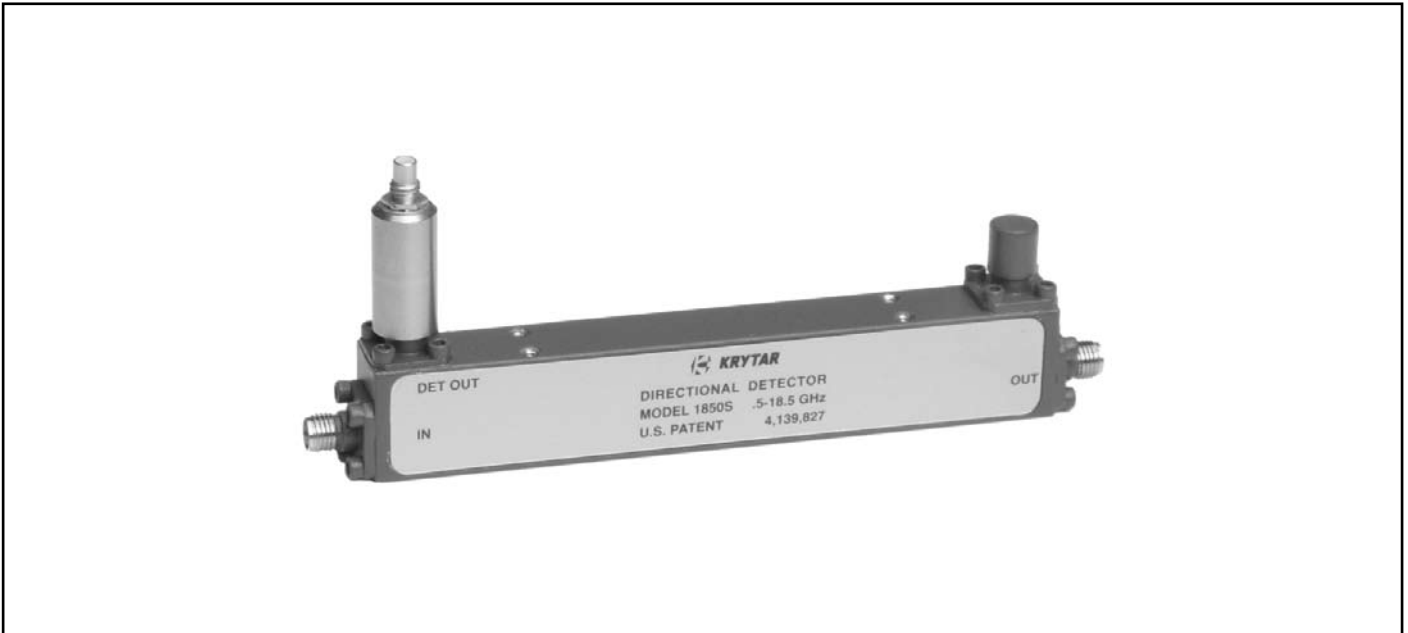

0.5-18.5 GHz DIRECTIONAL DETECTORS

SPECIFICATIONS

FREQUENCY RANGE		0.5-18.5 GHz
FREQUENCY SENSITIVITY (with respect to output)		± 1.0 dB
DIRECTIVITY		> 15 dB, 0.5-12.4 GHz > 12 dB, 12.4-18.5 GHz
MAXIMUM VSWR (any port)		1.35
INSERTION LOSS	1851S 1850S	< 1.5 dB < 1.1 dB
LOW LEVEL SENSITIVITY	1851S 1850S	> 40 µV/µW > 10 µV/µW
DETECTOR OUTPUT POLARITY		Negative
POWER RATING (input)	1851S 1850S	1 W 4 W
STANDARD CONNECTORS		
RF		SMA Female
Optional:		SMA Male or N Female
DET OUT		SMA Female, BNC Female, or SMC Jack
WEIGHT (ounces)		
N Female RF Connectors		5.2
SMA Female RF Connectors		3.8
OPERATING TEMPERATURE		-54° to +85° C

DIMENSIONS
